METEOR XP

LFR3210

LFR3215

UNDERWATER
POOL
LIGHT



Operating Instructions

ASIEL
LIGHTING

CONTENTS

Preface	3
Features	3
Precautions	3
Components and Connectors	4
Installation	5
Controls	7
Appearance	9
Technical Specifications.....	9
Warranty.....	10
Declaration of Conformity.....	11



PREFACE

The METEOR XP series of modern compact flush-mount designed underwater pool light with built-in driver is designed to use the latest LED lighting technology.

The compact flush-mount designed casing enables very simple installation to the stainless-steel, concrete or liner/concrete pools with suitable niches. The special connector assembly enables very simple maintenance or replacement during servicing period.

The METEOR XP series is available in stainless steel casings. The lighting is available in cool white, warm white, blue, green, red and multi-color RGB or RGBW colors with 32 high-power LEDs.

The single-color or multi-color versions allow light control with dimming and changing of the color of lighting manually or automatically through the complete rainbow spectrum.

The most advanced electronic design with built-in microprocessor enables network connection and simple control of complete group of lights.

FEATURES

- Stainless Steel Casing
- 32 Power LEDs Design
- Cool White, Warm White, Blue, Green, Red, Multi-Color RGB or RGBW Lighting
- Tempered Glass Optical Window
- High-Efficiency Lens
- Remote Control
- Digital Dimming
- Polarity Protection
- Transient Protection
- Thermal Protection
- Low Power Consumption
- Simple Installation
- Optional accessories for different pools installations

PRECAUTIONS

- The underwater pool light has to be installed and used in accordance with the instructions of this manual only.
- The power supply has to be disconnected before installation.
- The underwater pool light is recommended to be installed around 0.2 m below the water line for the best illumination and to avoid over-heating.
- The optical window must be clear and not covered by any kind of isolating or other material.
- The optical window has to be cleaned with a mild soap or detergent and lukewarm water by using a soft cloth or sponge. Do not use abrasive or highly alkaline cleaners. Never scrape with razor blades or other sharp instruments.
- Do not turn power off immediately and refer servicing to qualified service personnel if the underwater pool light does not operate normally following the operating instructions.

COMPONENTS AND CONNECTORS

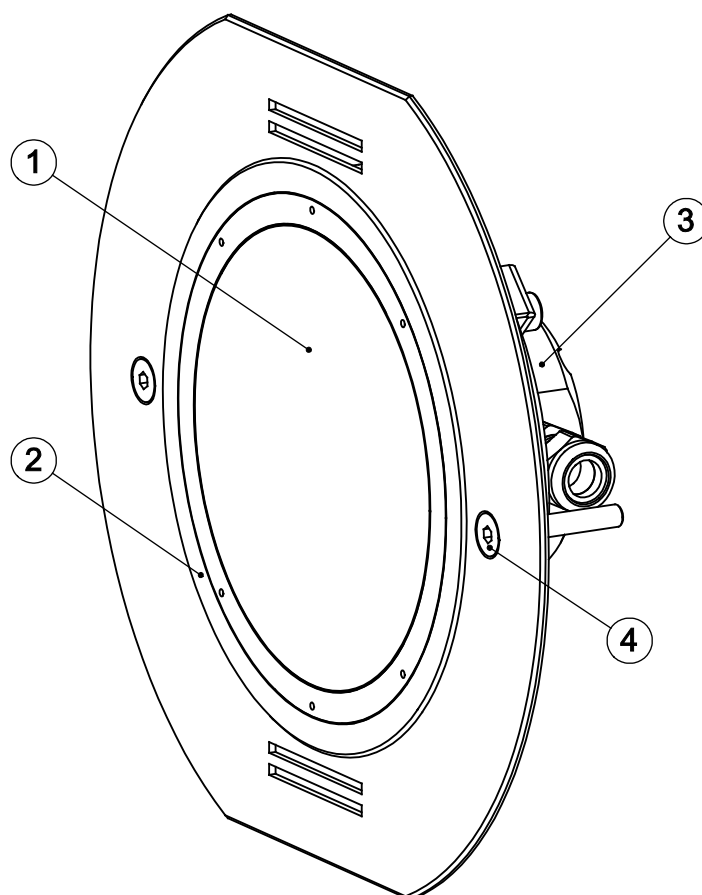

(1) Optical window

Tempered glass optical window.

(2) Underwater pool light casing

Stainless steel casing incl. fixing plate with mounting holes and water cooling slots.

(3) Connector assembly

The multi-core cable to connect the DC power supply and optional remote control or switch.

(4) Fixing screw

2 fixing screws to fix the underwater pool light into the suitable niche.

INSTALLATION

The underwater light kit consists of the following components:

- Underwater Light METEOR XP with connector assembly and connection cable
- 2 x fixing screws M6x40
- Operating Instructions with Declaration of Conformity and Warranty conditions

The METEOR XP has to be fixed into the suitable niche on the pool wall under waterline. Leave at least 2m of connection cable wrapped inside the niche for future maintenance and service. When the installation is finished briefly test the underwater light prior to fill the pool with water. The installation have to be realized by a qualified personnel.

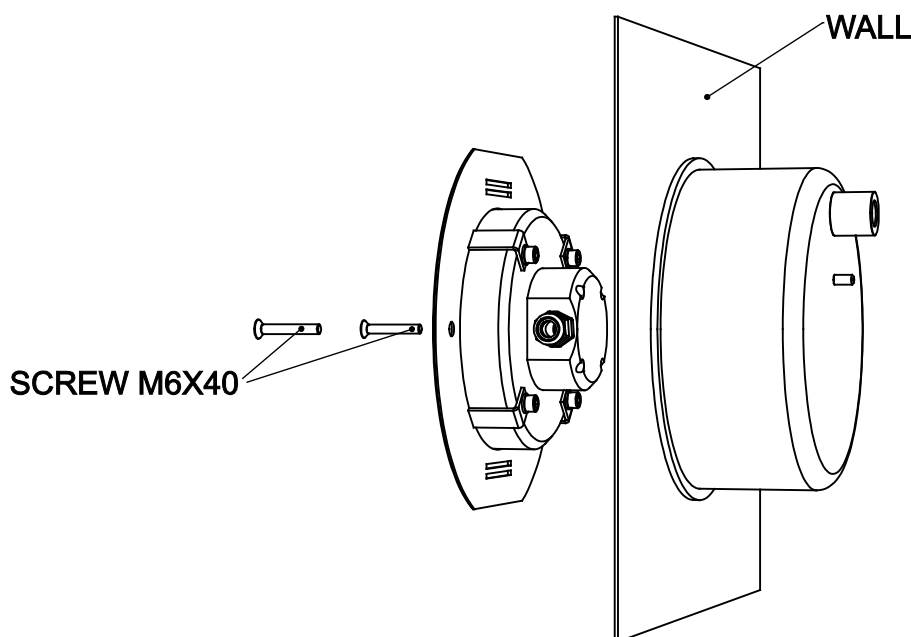

Note:

- ***Avoid using the underwater pool light out of the water – submerge before lighting.***

Fixing

The underwater light has to be fixed with 2 screws M6x40 to the suitable niche.

Note:

- ***Do not overtighten the screws as this can result in fixing plate or niche damage.***

Earthing

The underwater pool light has to be earthed by using a pre-tinned green wire with a yellow stripe a minimum of 8 AWG (8.36 mm²). The wire has to be connected to the rear side of suitable niche by the help of prepared fixing screw M6 signed by earthing label.

The underwater light has to be connected as described in the table below:

Connection

The power supply has to be connected through the main switch (not included) with correct polarity and protected by a fuse (not included). The power supply voltage has to be 12-24Vdc.

Note:

- ***The power supply has to be switched off before installation.***

METEOR XP wire color	FUNCTION
Red	+ DC Power Supply
Black	GND Power Supply
Orange	+ Control
Blue	GND Control

For basic control of the light the CONTROL wire has to be connected through the momentary switch (not included) to the GND by using a 2-pole signal cable extension. (not included)
 For DMX512 control optional LXU01 interface can be connected to the CONTROL and GND wires by using a 2-pole signal cable (not included).

Note:

- ***When two or more lights are connected in the lighting system all the control wires can be connected in parallel and all the lights then can be controlled by using only one momentary switch or LXU01 interface.***

CONTROLS

Single-color cool white (W), warm white (WW), blue (B), green (G) or red (R) models

Control by momentary switch

Remote control by momentary switch can be used to turn-on and turn-off the light and to control the luminosity.

Turning on / off

Press the momentary switch momentary.

Dimming

When the light is on, press the momentary switch longer until the desired power is achieved.

Turning on minimum

When the light is off, press the momentary switch longer (e.g. one second or more) until the light is turned on at minimum power.

Set default

Press the momentary switch for min. 40 seconds or until the light is turned off.

DMX512 control

The network connection to control the light with the standard DMX512 protocol is enabled by using optional LXU01 interface.

Multi-color (RGB, RGBW) models

Remote control has to be used to turn-on and turn-off the underwater pool light and to control the mode of lighting and luminosity.

The multi-color underwater pool light can be controlled by using the momentary-switch.

When the light is turned-off the color or mode of lighting can be changed sequentially by pressing the momentary switch for 2 seconds:

RGB Sequence of lighting	RGBW Sequence of lighting
Custom Color	Custom Color
Full RGB	Full RGBW
Cool White	Neutral White
Bluish White	White
Red	Red
Green	Green
Blue	Blue
Rainbow Color Spectrum	White Color Spectrum
	Custom White Color
	(Rainbow) Color Spectrum

Turning on /off

Press the momentary switch shortly.

Changing the color or mode of lighting

When the light is turned-off press the momentary switch for 2 seconds.

Setting the Custom Color

At the selected (Rainbow) Color Spectrum mode press the momentary switch shortly to turn the light off. After that press the momentary switch for 5 seconds or until the light is switched to the selected color and then the Custom Color is set and selected.

Setting the Custom White Color

At the selected White Color Spectrum mode press the momentary switch shortly to turn the light off. After that press the momentary switch for 5 seconds or until the light is switched to the selected white color and then the White Color is set and selected.

Dimming

When the light is turned-on press the momentary switch until the desired illumination is achieved. By another pressing of the momentary switch the luminosity will increase to the maximum illumination.

Set default

Press the momentary switch for min. 40 seconds or until the light is turned off.

Synchronization

When more than one multi-color underwater light is connected to the system the optional Synchronization Unit LSU08 is recommended to synchronize the colors of lighting at the Rainbow Color Spectrum mode of lighting. On the other case the colors of all installed lights would not be the same after few minutes or hours of operation in the (Rainbow) Color Spectrum mode.

If the multi-color light is used only with one of the fixed color of lighting the synchronization is not necessary.

DMX512 control

The built-in ASTEL protocol enables the network connection to control the lights with the standard DMX512 protocol by using optional LXU01 interface.

APPEARANCE

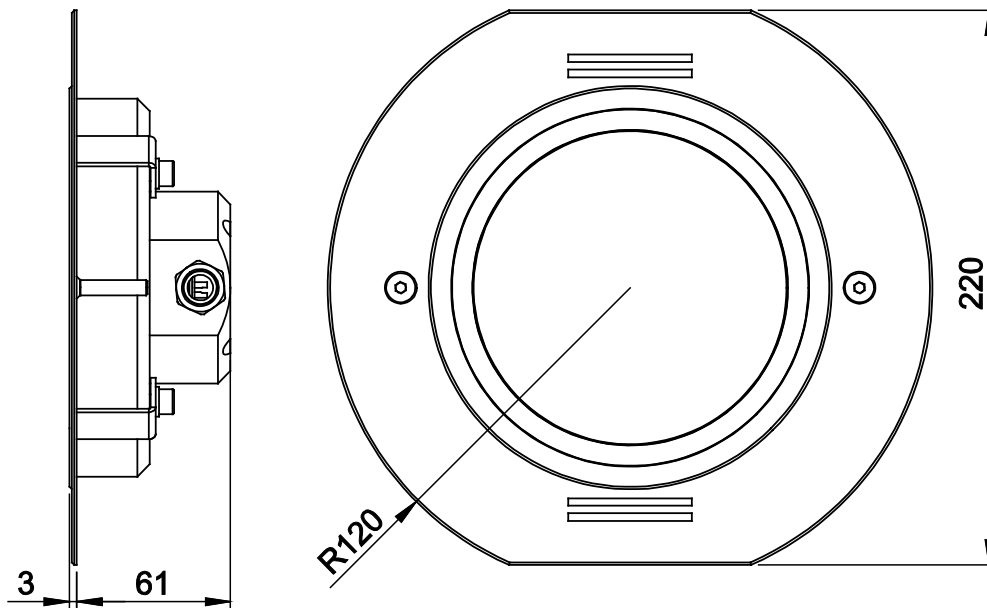

TECHNICAL SPECIFICATIONS

Power supply	12-24 Vdc, max. 9.7 A/12 Vdc or 4.6 A/24 Vdc
Beam angle	35° (standard)
Optical window	Tempered glass 8 mm
Luminous flux	max. 10.000 lm (cool white) (LFR3210) max. 15.000 lm (cool white) (LFR3215)
White color temperature	6.000 K
Operating temperature	-10°C - +50°C
Casing	Stainless steel (316L)
Protection	IP 68
Dimensions	Ø240 x 220 X 64 mm
Weight	4.3 kg

Design and specifications subject to change without notice.

WARRANTY

1. The equipment manufactured by ASTEL d.o.o. is warranted to be free from defects in workmanship and materials under normal use and service.
2. This Warranty is in effect for of two years from the date of purchase by the user. Proof of purchase must be included, to establish that it is inside the warranty period.
3. This Warranty is transferrable and covers the product for the specified time period.
4. In case any part of the equipment proves to be defective, other than those parts excluded in paragraph 5 below, the owner should do the following:
 - (a) prepare a detailed written statement of the nature and circumstances of the defect, to the best of the Owner's knowledge, including the date of purchase, the place of purchase, the name and address of the installer, and the Purchaser's name, address and telephone number;
 - (b) the Owner should return the defective part or unit along with the statement referenced in the preceding paragraph to the warrantor, ASTEL d.o.o., or an authorized distributor, postage/shipping prepaid and at the expense of the Purchaser;
 - (c) if upon the Warrantor's or authorized distributor's examination, the defect is determined to result from defective material or workmanship, the equipment will be repaired or replaced at the Warrantor's option without charge, and returned to the Purchaser at the Warrantor's expense;
 - (d) no refund of the purchase price will be granted to the Purchaser, unless the Warrantor is unable to remedy the defect after having a reasonable number of opportunities to do so. Prior to refund of the purchase price, Purchaser must submit a statement in writing from a professional supplier that the installation instructions of the Operating Instructions manual have been complied with and that the defect remains;
 - (e) warranty service shall be performed only by the Warrantor, or an authorized distributor, and any attempt to remedy the defect by anyone else shall render this warranty void.
5. There shall be no warranty for defects or damages caused by faulty installation or hook-up, abuse or misuse of the equipment including exposure to excessive heat, salt or fresh water spray, or water immersion except for equipment specially designed as waterproof.
6. There shall be no responsibility or liability whatsoever on the part of the Warrantor or its employees and representatives for injury to any person or persons, or damage to property, loss of income or profit, or any other consequential or resulting damage or cost which may be claimed to have been incurred through the use or sale of the equipment, including any possible failure or malfunction of the equipment, or part thereof.

DECLARATION OF CONFORMITY

according to IEC Guide 22 and EN 45014

Manufacturer's Name: ASTEL, Podjetje za projektiranje, proizvodnjo in trgovino, d.o.o.

Manufacturer's Address: Dutovlje 138
6221 Dutovlje
Slovenija

declares that the products

Item, Product Name and Model Number: 1. Underwater Pool Light METEOR XP

conform to the following Product Specifications:

EMC: EN 55015:2006 + A1:2007
EN 61547:1995 + A1:2000 + A2:2009
EN 61547:2009

Safety: EN 60598-2-18:1995/A1:2012
EN 60529:1992+A2:2013

Supplementary Information:

The products herewith comply with the requirements of the following Directives and carry the CE-marking accordingly:

- the Low Voltage Directive 2014/35/EU
- the EMC Directive 2014/30/EU
- the RoHS Directive (EU) 2015/863

ASTEL d.o.o.
Dutovlje 138
6221 Dutovlje
Slovenija

18th February, 2018

ASTEL d.o.o., Dutovlje 138, 6221 Dutovlje, Slovenia
Tel: +386 5 7310771, +386 5 7310772
Fax:+386 5 7310789

E-mail: info@astel-lighting.com

Web: www.astel-lighting.com